

COMFORT DRY™ 250

advanced humidity control
hot water based dehumidifier

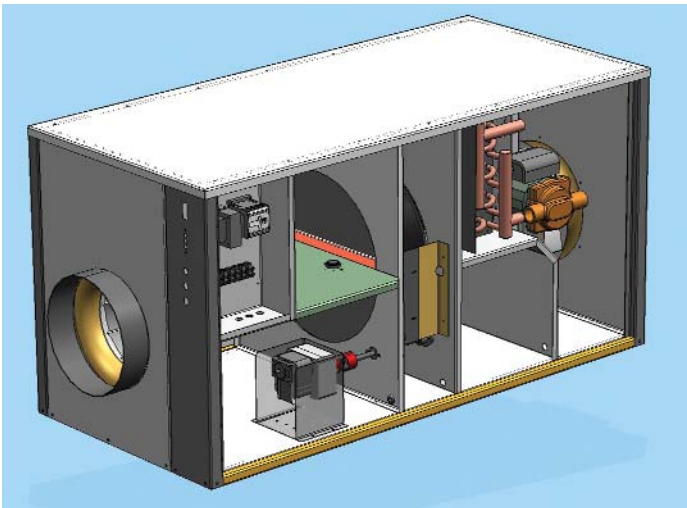

NovelAire's ComfortDry™ 250 is a desiccant based dehumidifier, driven with hot water, to provide comfort and improved indoor air quality through the control of indoor relative humidity. Any available hot water source can be used to provide the heat necessary to reactivate the internal desiccant wheel. Hot water from tankless or hybrid type heaters, solar collectors, or a combination of both can be used by the ComfortDry 250 to provide the energy source for controlling humidity in a space. With independent control of humidity, the set point temperature of the space can be raised, without sacrificing comfort, resulting in significant energy savings. In addition, controlling the space humidity in the 45-50% RH range, improves indoor air quality by preventing the growth of mold, mildew and, in particular, dust mites which can trigger many allergies.

BENEFITS

- Dehumidifies with any hot water source to control humidity independently
- Prevents mold, mildew and dust mite growth by maintaining 50% RH
- Saves energy by maintaining comfort at higher set point temperatures
- **If solar collected or waste hot water is used, energy savings are even higher**
- No condensing lines or buckets of water to deal with!

HOW IT WORKS



The revolutionary new technology of NovelAire's Comfort Wheel™ is specifically designed to maximize moisture removal and comfort in your home. The Comfort Wheel rotates slowly while simultaneously adsorbing the moisture from your home. The moisture-laden wheel then rotates into the outdoor air stream where the hot water coil heats the outdoor air so that it dries the wheel and discharges the unwanted excess moisture outdoors. This energy efficient process provides **greater comfort** and **lower cooling bills**.

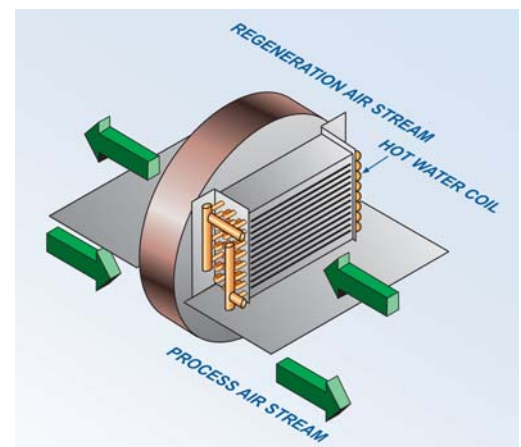

COMFORT DRY™ 250

SPECIFICATIONS

Power:	120 V, 15A Circuit, 1PH 60 HZ, FLA 5.2, RLA 3.4
Control & Interlock:	24 vac
Weight:	137 lbs
Process Volume:	300 CFM
Regeneration Volume:	300 CFM
Capacity (@80F, 60% RH):	105 Pints/Day
Hot Water Requirement:	1-2 GPM @ 120F-160F
Sized For:	Up to 3000 SQ. FT. - Typical

PERFORMANCE

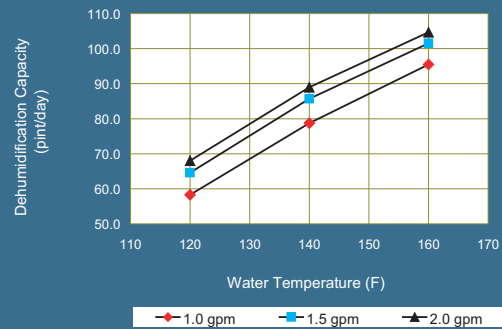

DIMENSIONS

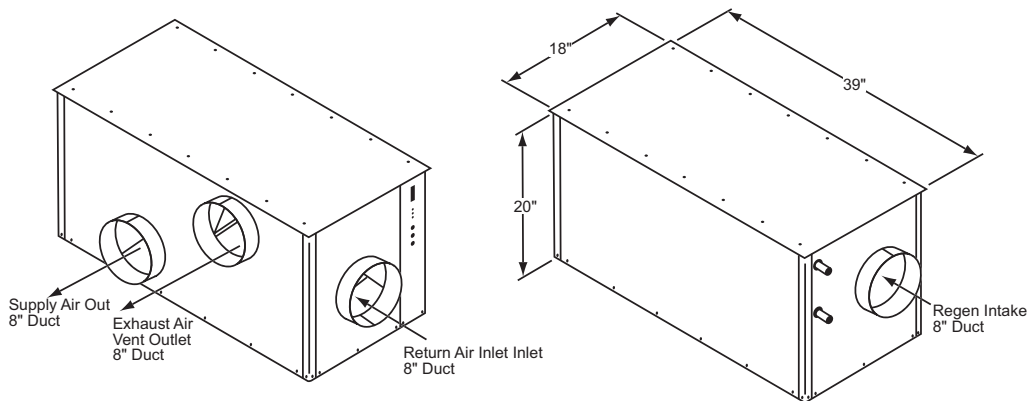

INSTALLATION

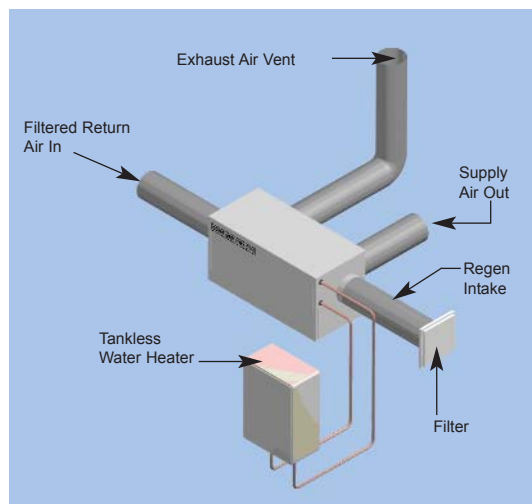

The ComfortDry 250 will operate with any hot water source. The unit can be installed as shown in a "stand alone" configuration where filtered return air comes from the space to the unit, and dry supply air returns back to the space through two supply air registers that "Y" off of the main supply air duct. Reactivation air is typically attic air that is pulled through a filter, through the unit and exhausts with the moisture from the desiccant wheel through the exhaust vent. As an option, the ComfortDry 250 can be ducted into the existing air handling system to utilize the existing duct work for dry air distribution throughout the home. Consult the operating and installation manual for details.

NOVELAIRE *Comfort* PRODUCTS
creating the great indoors®

10132 Mammoth Drive, Baton Rouge, LA 70814-4420
tel. 800-762-1320 / 225-924-0427 fax. 225-930-0340
www.novelaire.com



The information contained in this brochure is believed to be accurate by NovelAire Comfort Products, but is not warranted.