



Contents lists available at ScienceDirect

## Renewable and Sustainable Energy Reviews

journal homepage: [www.elsevier.com/locate/rser](http://www.elsevier.com/locate/rser)

## Systematic and conceptual errors in standards and protocols for thermal performance of biomass stoves



Zongxi Zhang<sup>a,b</sup>, Yixiang Zhang<sup>a,b,e</sup>, Yuguang Zhou<sup>a,b,\*</sup>, Riaz Ahmad<sup>a,b</sup>,  
Crispin Pemberton-Pigott<sup>c</sup>, Harold Annegarn<sup>d</sup>, Renjie Dong<sup>a,b</sup>

<sup>a</sup> Bioenergy and Environment Science & Technology Laboratory, College of Engineering/Biomass Engineering Center, China Agricultural University, No. 17 Qinghua Donglu, Haidian District, Beijing 100083, P. R. China

<sup>b</sup> Key Laboratory of Clean Production and Utilisation of Renewable Energy, Ministry of Agriculture, China Agricultural University, No. 17 Qinghua Donglu, Haidian District, Beijing 100083, P. R. China

<sup>c</sup> Sustainable Energy Technology and Research (SeTAR) Centre, University of Johannesburg, Republic of South Africa

<sup>d</sup> Energy Institute, Cape Peninsula University of Technology, Bellville, Republic of South Africa

<sup>e</sup> Aerosol and Air Quality Research Laboratory, Department of Energy, Environmental & Chemical Engineering, Washington University in St. Louis, Campus Box 1180, One Brookings Drive, St. Louis, Missouri 63130, USA

### ARTICLE INFO

#### Keywords:

Biomass stove  
Water boiling test  
Energy efficiency  
Emission  
Conceptual error

### ABSTRACT

Testing of biomass stove performance is mainly based on the use of water boiling or heating as a surrogate for cooking tasks. Boiling of water is prescribed as a simulation of common cooking tasks and is used for comparison of the performance of stoves under different operating conditions. Tests are designed to evaluate biomass stoves by providing quantitative and qualitative information about their thermal and emission performance. In some developing countries, notably China, India, Mongolia, and South Africa, water boiling or heating tests focus on the overall thermal performance as a fuel consumption proxy, again with narrowly defined operating conditions. During the past few years, several newly developed performance evaluation standards and protocols for cooking and space heating stoves based on solid biofuels have been developed. National standards differ significantly from one country to the other because of inhomogeneous local conditions, widely varying cooking habits, the level of industrialisation and cultural preferences. All those stove testing standards and protocols have been tried and found to be prone to systematic and conceptual errors, virtually none of them having been professionally and scientifically reviewed. The current paper reviews several different approaches to a widespread need for results of stove performance tests to be comparable and identifies a number of calculations and conceptual errors that materially affect the outcome of stove tests. Recently, research and development work promoting the dissemination of improved biomass stoves has attracted global participation. It is essential that, as far as possible, all conceptual and systematic errors should be identified, corrected and avoided during the process of the development of acceptable international standards and protocols.

### 1. Introduction

Stove performance testing standards have been developed over the last three decades to evaluate and compare the thermal and emission performances of traditional and innovative biomass stoves. Those testing protocols are helpful and also to understand the processes of fuel combustion, heat transfer within the stove and during the process of operating the stove, and specifically the useful heat that is transferred into the cooking vessel (pot) [1]. Some research institutes have proposed their testing protocols and methods to test the performance of biomass stoves. Those institutes include the

Sustainable Energy Technology and Research (SeTAR) Centre at the University of Johannesburg (Heterogeneous Testing Protocol, known as HTP) in South Africa, and the Energy Institute and Powerhouse Energy Campus at Colorado State University (Stove Manufacturers Emissions & Performance Test Protocol, known as EPTP) in the USA [2–5].

The original *water boiling test*, a short and simplified simulation of cooking practices, was drafted in December 1982 and published as a provisional standard by an organization called Volunteers in Technical Assistance (VITA) [6]. This method was reviewed and finally published as “*Testing the efficiency of wood-burning cookstoves VITA 1985*”.

\* Corresponding author at: Bioenergy and Environment Science & Technology Laboratory, College of Engineering/Biomass Engineering Center, China Agricultural University, No. 17 Qinghua Donglu, Haidian District, Beijing 100083, P. R. China.

E-mail address: [zhouyg@cau.edu.cn](mailto:zhouyg@cau.edu.cn) (Y. Zhou).

<http://dx.doi.org/10.1016/j.rser.2016.10.037>

Received 5 May 2015; Received in revised form 20 September 2016; Accepted 25 October 2016

Available online 03 November 2016

1364-0321/© 2016 Elsevier Ltd. All rights reserved.

Procedures of the VITA water boiling test standard included two high power phases and one low power phase. It was used to make a quick assessment of the performance of a stove under two different igniting conditions, known as cold start and hot start [7]. Those tests were intended to obtain quantitative and qualitative information about the thermal performance of the tested biomass stoves.

In the ensuing decades, testing of household biomass stove performances has continued, based largely on variants of the water boiling test. Additional procedures were added to determine gases and particulate emissions of different phases. However, the reproducibility of testing results within an acceptable range has remained a critical challenge for the acceptance of such results as a valid measure and a predictor of future performance of the stoves [8].

Many countries have developed their own performance testing standards to evaluate thermal and emission performance of household biomass stoves, almost all of which are based on water boiling test approach. One might expect, therefore, to find common ground among those standards. However, those standards differ significantly from one to another due to inhomogeneous local conditions, different cooking habits, stove types, fuel categories, as well as the level of industrialisation and strong cultural preferences. This diversity of different national standards presents challenges to the development of international stove standards for regulating international/cross-regional trade or even further carbon trading. For example, if a company wishes to export biomass stoves to another country/region, those stoves should firstly be certified by their own domestic standards, and then be evaluated according to the standards of the importing country to check whether they meet the local users' requirements. The national standards might generate divergent results among them or with the international standards, sometimes with significant discrepancies. The performance of a stove might be acceptable when rated using one method but considered inferior when measured using a different testing method. Protocols proposed by research institutes face similar problems.

In an attempt to overcome those challenges, the International Organization for Standardization (ISO) and the Global Alliance for Clean Cookstoves (GACC) convened a working group meeting in Hague, the Netherlands in 2012. This session generated, by consensus of experts, an International Working Agreement (IWA 11: 2012), containing guidelines for evaluating cookstove performance and a system of rating stoves on a tiered system for thermal performance and pollutant emissions, respectively. This IWA document was designed as a prelude to the creation of an ISO international standard for assessing a set of performance indicators of biomass stoves, such as fuel used, emissions, indoor emissions and safety [9,10]. The ISO IWA document is mainly based on the version of the WBT current at that time (WBT 4.1.2), even though the IWA referred to several additional protocols.

In recent years, research on and dissemination of improved biomass stoves have been conducted globally [11]. Currently, more than 160 cookstove programmes have been implemented in different nations/regions around the world [12]. For instance, the GACC aimed to mobilize high-level national and donor commitments with the goal of universal adoption of clean and efficient cooking stoves and fuels. The GACC has set themselves the goal of reaching 100 million households with clean cooking stoves by the year of 2020 [13]. The Climate and Clean Air Coalition (CCAC) was launched in February 2012 by the collaboration of governments, including Bangladesh, Canada, Ghana, Mexico, Sweden and the United States, along with the United Nations Environment Program (UNEP), with the aim of reducing short-lived climate pollutants to protect public health and the environment [14]. It focuses on air pollution solutions specifically to reduce black carbon exposure. The CCAC represents a new opportunity to promote clean stoves and fuels [15].

Improved wood stove programmes have been undertaken in Kenya since the early 1980s, initiated by the German government agency

Deutsche Gesellschaft für Internationale Zusammenarbeit (GIZ) (successor organization of the Gesellschaft für Technische Zusammenarbeit—GTZ, DED and InWent) in collaboration with Kenyan government [16]. The Ethiopian Rural Energy Development and Promotion Center, and GTZ, have participated in the development and dissemination of biomass cooking stove technologies in Ethiopia [13]. The World Bank Group (WB) launched the East Asia and Pacific *Clean Stove Initiative* (CSI), which included four countries specific programmes (China, Indonesia, Laos People's Democratic Republic, and Mongolia) [17]. WB financed the Ulaanbaatar city with US\$ 15 million to promote clean-burning stove technologies, and implemented medium term measures for enhancing air quality management capacity [18]. The Indonesian Clean Stove Initiative (CSI) was a collaborative venture between the Directorate General of New Renewable Energy and Energy Conservation, Ministry of Energy and Mineral Resources of Indonesia, and the WB [19]. The International Energy Agency (IEA) estimated that by the year 2030, bringing electricity and clean-cooking facilities to every person all over the world would cost US\$ 49 billion per year [20].

From early 1950s, development and dissemination activities of Improved Cooking Stoves (ICS) were undertaken in Nepal. The national ICS program disseminated 12,000 improved cooking stoves from 1999 to 2005. With the combined efforts of the national ICS program and other organizations, 890,000 improved cooking stoves were disseminated by July 2014 [21]. The Chinese National Improved Stoves Program, which was the largest stove promotion project in the world and followed a market-based approach, disseminated about 129 million stoves between 1982 and 1992, accounting for 65% of the rural Chinese population at that time [22–24]. The Indian National Program on Improved Cooking Stoves started in 1983 and supported by the government, disseminated more than 2.8 million stoves by 2002 [25–27]. There have been numerous efforts to promote improved biomass stoves in rural and urban areas of Tanzania since the 1980s [28]. A Tanzanian traditional energy development organization was launched in 1992 to promote improved charcoal and wood stoves, such as the Jiko Bora (ICS) and Okoa. Their dissemination was advocated by the regional technical and the business sector, supported by the European Union, the Norwegian government and Hivos of the Netherlands [29]. A number of organizations collaborated to deploy 500,000 certified improved biomass stoves with chimney in Peru up to 2009 [30,31], and some 300,000 stoves were built from 2009 to the end of 2011 in Peru [31]. In May 2013, approximately 14 cookstove projects were registered as Programmes of Activities with the Intergovernmental Panel on Climate Change Clean Development Mechanism on their agenda under “smaller decentralised projects” [32,33].

By summing up the reported statistics, it is estimated that those cookstove dissemination programmes have promoted 179 million improved cookstoves, including 129 million installations in China, 13 million in the rest of East Asia, 22 million in South Asia, 7 million in the Sub-Saharan Africa, and more than 8 million in Latin America and the Caribbean Region [34].

In fact, most of those clean stove initiative projects and programmes have been unable to deliver on their expected improvements when disseminated clean stoves were tested in households within targeted communities. Such tests are known colloquially as “*field tests*”. Field testing is critical to justify claims about the actual (in contrast to projected or modelled) impacts on fuel consumption, greenhouse gas emissions and emission reductions resulting from the use of improved stoves. Reasons behind the failures of those cookstove improvement promotions include failure to decrease fuel consumption or reduce overall emissions when used under practical household conditions. In many cases, improved stoves were more efficient than the traditional ones under laboratory conditions, however the performance at household level were debatable, because improved stoves, fuels and use patterns prescribed in the idealised water boiling tests were incompatible with traditional ways of cooking and impractical for kitchen

conditions (here the term kitchen conditions is used to replace *field test*, since *field test* leads to confusion when being translated into Chinese). The reason behind this is the conditions in a laboratory are more orderly, stable and comfortable than that of in a typical household. A more substantial reason is that systematic and conceptual errors might be found in almost all existing biomass stove performance testing standards and protocols with the implication that the rating did not represent its actual performance, even in a laboratory setting.

The purpose of this article is to review some significant conceptual errors, invalid calculation steps, and questionable metrics thus further discovered in selected stove performance testing standards and protocols. All those examples demonstrated the importance of further refining and improving testing methods for household biomass stoves. There have been numerous investigations on laboratory testing, field testing and policy aspects of biomass stoves since the 1980s [4,17,35–39]. Those publications helped to optimize stove design, dissemination of improved stoves and the development of biomass stove standards and protocols. However, until now, there is no internationally accepted and applied performance rating standard or protocol for biomass stoves.

## 2. Review of ISO processes for the development of biomass stove standards

According to the ISO regulations, the development of an international standard should contain the following six stages: proposal stage (new standard should be proposed by the technical committee), preparatory stage (experts and convenors of the working group start to discuss and prepare a working draft), committee stage (share the working draft with the technical committee), enquiry stage (the draft International Standard shared with national members to comment), approval stage (the final draft sent to all ISO members) and publication stage (the approved document is released as an ISO standard by the secretariat). During the development processes of an international standard, the proposal stage, enquiry stage, and publication stage are obligatory [40]. The committee secretary should submit the Draft International Standard (DIS) to ISO Central Secretariat, who will then circulate the DIS to all ISO members for comments over a three-month period, and voting. The DIS will be approved if two-thirds of the *P-members* of the Technical Committee (TC) vote in favour of the DIS and not more than one-quarter of the total number of votes cast is negative [41]. As researchers and experts wish to develop an academically acceptable international standard for household biomass stove, the TC must be aware of any systematic and conceptual errors in the existing protocols and avoid repeating them in any new or developing international standards.

ISO established a Technical Committee – ISO/TC285 aims of developing standards, incorporating a set of methods and indicators to measure the performance and emission of cookstove, while providing comprehensive data for stove, fuel combinations, and cooking practices. ISO/TC285 includes additional experts who work outside the clean cooking sector, which means that there is a sector-independent review as part of the standards development process. The work of ISO/TC285 will complement national, regional and international work for clean cookstoves and clean cooking solutions.

The first plenary meeting of ISO/TC285 was held in Nairobi, Kenya in February 2014. There were about seventy experts from eighteen P-member countries, two O-member countries, and five potential liaisons organizations attended that five-day meeting. During that gathering, four new work item proposals were submitted and approved by ISO/TC285. Four Working Groups (WG) were established to develop the following projects: (a) ISO TC285/WG 1 – Conceptual Framework, (b) ISO/TC285/WG 2 – Lab Testing Methods development, (c) ISO/TC285/WG 3 – Field Testing Methods development and (d) ISO/TC285/WG 4 – Social Impacts evaluations. ISO/TC285 also established two Task Groups (TG): ISO/TC285/TG 1 – Fuels, with the task

of identifying and reviewing published ISO standards on fuels and determine what standards need to be developed to address ISO/TC285 issues; ISO/TC285/TG 2 – Communications, with the task of promoting and reporting of ISO/TC285 activities.

The ISO has made significant progress over the past two years (2015 and 2016) with the continuous efforts of ISO/TC285 WGs and ISO/TC285/TG, especially after the workshop that held in Beijing during July 20–22, 2015. Experts from India, Nepal, South Africa, the USA, and China worked together on documents written by ISO/TC285 WGs and discussed how to develop an acceptable international standard for biomass stoves. The new IWA referred to many other standards and protocols, such as the method in Chinese standard, Indian standard, HTP protocol, but not only the WBT. However, there is still a long way to go during the development of an acceptable international standard. All the experts attended the workshop agreed during the development of an ISO standard for biomass stove, the ISO Technical Committee should consider additional, different conditions from developing countries. During the workshop, the experts visited four households in Wuxiang, Shanxi Province, China and conducted tests in farmers' households.

## 3. Methods for determination of systematic and conceptual errors

How did the authors identify those systematic errors and conceptual faults in the existing testing standards and protocols? Firstly, based on a literature survey of journal articles, reports, and presentations, the methods included comparison and analysis of various biomass stove standards and protocols, specifically those have been widely used or given attention by the ISO/TC285 Committee (Table 1). Published information was complemented by discussions with various stove researchers, designers, manufacturers, project implementers, and stakeholders. Definitions of terms and performance metrics were subjected to logical analysis for consistency. Spreadsheets for transforming measured values into output parameters (thermal performance and emissions) forming an integral part of standards were checked for algebraic accuracy and consistency with textual definitions.

## 4. Systematic errors and conceptual faults in stove performance testing standards and protocols

### 4.1. The definitions of standard, method and protocol

Before the determination of systematic and conceptual errors, one should correctly understand the definitions of standard, method and protocol, and the relationship between them. A standard is “a document which is established by consensus and approved by a recognized institution, provides common and repeated use, rules, guidelines or characteristics for activities or their results, aimed at the achievement of the optimum degree of order in a given context”. Standards should be built on the consolidated results of science, technology, and experience, and aimed at the promotion of optimum community benefits [47,48]. Usually, standards and standard setting processes are supported by the national governments. A protocol is “an original draught or record from a document, a plan for carrying out a scientific experiment or medical treatment” [49]. A method is “a manner or mode of procedure, especially an orderly, logical, or systematic way of instruction, enquiry, investigation, experiment, presentation and a unique way to solve the problem” [50]. Methods can be incorporated into standards and protocols. KS1814 (Kenya), NY/T 2369-2013 & NY/T 2370-2013 (NY is the designation of a Chinese agricultural industry standard), IS13152 (India), as mentioned in Table 1, are such standards. The HTP (South Africa), Controlled Cooking Test (CCT V2.0, the USA) and Water Boiling Test (WBT 4.2.3, the USA) are protocols, in this case for biomass stove performance testing.

**Table 1**  
Details of stove performance testing standards and protocols.

Standard No.	Nations	Proposed Institutes	Review Institutions	Level	Year	Title	Scope
IS13152 [42]	India	Non-Conventional Energy Sources Sectional Committees responsible for drafting	Mechanical Engineering Division Council, Bureau of Indian Standards is responsible for reviewing	National Standard	2013	Indian Standard on Solid Biomass Chulha-Specification	Portable solid biomass cookstoves
KS1814 [43]	Kenya	Mechanical Industry Standards Committee, Appropriate Technology Technical Committee	Kenya Bureau of Standards	National Standard	2005	Biomass stoves Performance requirements and test methods	Household biomass stoves that utilize the following biomass fuels: charcoal, wood, briquettes, bagasse, coal, husks, plant shells and any other biomass
NY/T 2369-2013 and NY/T 2370-2013 [44,45]	China	Ministry of Agriculture, China Association of Rural Energy Industry is responsible for drafting	Ministry of Agriculture	Industrial standard	2013	General technical specification of domestic biofuel cooking stove (NY/T 2369-2013) and Test performance method of domestic biofuel cooking stove (NY/T 2370-2013)	Suitable for the household biomass cooking stoves, space-heating stoves, space-heating and cooking stoves
HTP [3]	South Africa	Research institute Sustainable Energy Technology and Research (SeTAR) Centre, University of Johannesburg	Not mentioned	Research institute testing protocol	2012	The Heterogeneous Testing Procedure for Thermal Performance and Trace Gas Emissions	Real time performance assessment of space heating and/or cooking stoves burning solid, liquid and gaseous fuels
WBT 4.2.3 <sup>a</sup> [9]	USA	The Global Alliance for Clean Cookstoves and multiple Alliance partners are responsible for drafting	The U.S. Environmental Protection Agency, Partnership for Clean Indoor Air (PCIA), and the Global Alliance for Clean Cookstoves	Research institute testing protocol	2013	Cookstove Emissions and Efficiency in a Controlled Laboratory Setting	Emissions and thermal performance of cooking stoves under controlled laboratory conditions
CCT 2.0 [46]	USA	Shell Foundation, University of California, Berkeley and Aprovecho Research Center	Not mentioned	Research institute protocol	2004	Controlled Cooking Test	Assess the performance of the improved stoves

<sup>a</sup> WBT 4.2.3 was the update version of WBT 4.2.2, which was released on 19 March 2014. The U.S. Environmental Protection Agency, Partnership for Clean Indoor Air (PCIA), with updates coordinated by PCIA and the Global Alliance for Clean Cookstoves made some comments on this protocol. The main updates included: the spreadsheet, calculation errors, language and formatting.

#### 4.2. Unreasonable units of emission metrics

The authors start this section with three invalid calculated metrics involving the simmering phase of the WBT 4.2.3 stove performance testing protocol. Simmering phase was designed to test the capability of a stove to shift to a low power phase following a high power phase. The protocol specifies that the stove should be adjusted to keep a measured amount of water, nominally 5 liters, at a temperature between 3 °C and 6 °C below the local boiling point. The measured parameters are the amount of fuel required to maintain the pot and contents at this temperature and the cumulative carbon monoxide (CO) and fine particulate matter (PM<sub>2.5</sub>) emitted over the specified interval (45 min) [9].

The three calculated metrics which are brought into consideration are: (a) specific emission of CO, [g CO/liter of water remaining in the pot at the end of the session]; (b) specific emission PM<sub>2.5</sub>, [mg PM<sub>2.5</sub>/liter of water remaining in the pot at the end of the session]; and (c) fuel consumption, [g/liter of water remaining in the pot at the end of the session], each metric cumulative over a simmering period of 45 min [51]. The term *liter* refers to the volume of water remaining in the pot at the completion of that portion of the test.

It is asserted that those three low power metrics are arbitrary and conceptually flawed. Considering an ideal case in which the pot and contents are maintained at a constant temperature throughout simmering which means no heat gained or lost due to specific heat changes. Evaporation is allowed, so this argument is not dependent on either lid-on or lid-off conditions. The amount of fuel or energy that is needed to maintain the pot and its contents within the specified temperature range for the defined duration is exactly balanced by the heat losses through evaporation (lid-off), radiation, convection and conduction to the surrounding air. Except in the limiting case of the

water boiling away, none of those heat loss mechanisms depends in any way on the volume of water in the pot. The ‘emissions per liter water simmered’ generate arbitrary values – consider that 4 or 6 liters of water in the pot would produce different numerical values for the specific emissions even if no other conditions of the fire or the stove were altered. The WBT spreadsheet does not perform this calculation using 5 liters of water, so the reported metrics are logically subject to an arbitrary experimental condition. Furthermore, the spreadsheet attempts a form of normalization by increasing the emissions value recorded based on the amount of water remaining to give certain performance ratings per 5 liters which is an arbitrary changing of the values that are recorded.

The mechanisms of heat loss are dependent on the shape and surface condition of the pot (shiny or matt black), and ambient air movement may enhance evaporation from the surface of the water. Those three metrics are thus arbitrary values that do not correspond to any physical relationship between stove, fuel and water during the simmering phase, and accordingly are conceptually invalid. To develop acceptable international standards for biomass stoves, it is necessary that, as far as possible, such conceptual faults should be identified, corrected or avoided through proper definition of the reporting metrics.

#### 4.3. Selection of the end-point for emission testing

Almost all the available stove performance testing standards and protocols provide an end-point for thermal performance testing, but do not stipulate an end-point for emission performance testing. Emission tests are terminated simultaneously with the thermal performance tests. However, in practice, emissions may continue for some time after the fire no longer provides useful heat. Accordingly, a choice of diverse end-points could have a significant influence on the total emissions

recorded for the test. As the aggregate emissions are health-related metrics, choosing the end point to coincide with the end-point of thermal performance testing may underestimate (neglect) the emissions of the tested stove. Stove test experiments performed at the China Agricultural University with continuous monitoring of emissions indicated that if emission tests were stopped as the thermal performance test ended instead of when the fire was allowed to burn to extinction resulted in an underestimation by 21% of total carbon monoxide, 10% of nitrogen oxide, 55% of nitrogen dioxide, 3.1% of methane, and 21% of carbon dioxide. (Those tests were conducted according to the Chinese standard NY/T 2379-2013: General technical specification of domestic biofuel cooking stove; and NY/T 2370-2013: Test performance method of domestic biofuel cooking stove) [52]. An end-point should be defined scientifically so that the emission performance reflects accurately the properties of the stove over a full burning sequence, not a portion of emissions over time required to comply with an externally determined sequence of laboratory measurements. Quantitative emission evaluations that prescribe a fixed sampling duration are thus prone to a concatenated series of serious systematic errors.

#### 4.4. The definition of energy efficiency

Although many standards and protocols for biomass stove performance testing are available, it is necessary to have a uniform definition for energy efficiency. Usually, energy efficiency is defined as the ratio of the effective energy (energy applied to a task) over the energy input. For biomass stoves, energy efficiency is the ratio of effective heat for cooking or heating (according to the stove's functional purposes) to the energy available in the fuel required for replication of the task. The energy released by combustion of fuel is not the same as the chemical potential energy in the fuel needed to perform the task. In short, some fuel is not fully combusted during tests. A portion of the partially combusted fuel may be used in a subsequent replication and the remainder discarded. Using the heat actually released from the fuel combustion as denominator and the heat transferred to the pot as numerator always gives a higher calculated result for the energy efficiency.

Some of the cooking stove standards and protocols define effective energy as the energy used to heat the pot, lid (if used) and water in the pot (sensible heat) and latent heat of vaporization of any evaporated water. In WBT 4.2.3 the heat used for increasing the temperature of pot and contents is calculated according to Eq. (1).

$$H_1 = C \times G_{c1} \times (T_{c1} - T_{c2}) \quad (1)$$

Where,  $G_{c1}$ =Initial water mass, [kg];  $T_{c1}$ =Initial water temperature, [°C];  $T_{c2}$ =Water temperature at boiling point, [°C]; and  $C$ =Specific heat of water at local boiling point, [kJ/(kg °C)].

Heat for water evaporation is obtained by Eq. (2).

$$H_2 = r \times (G_{c1} - G_{c2}) \quad (2)$$

Where,  $G_{c2}$ =Remaining water mass, [kg]; and  $r$ =Average latent heat of vaporization at the average evaporation temperature, [kJ/kg].

Energy used to evaporate water is not calculated in the Indian standard and the HTP protocol. This might be because at the end of the test the water temperature is below water boiling point in both Indian standard and the HTP protocol. According to the Indian standard (IS13152), as the water reaches 95 °C, the operator needs to swap the pot with an identical pot containing the same initial amount of water at room temperature, repeating until there is no longer any visible flame. In the HTP protocol, the operator performs a similar exchange of pots as the water reaches 70 °C. The tests should be done with lid on according to both the HTP protocol and Indian standard, allowing evaporated steam to condense and drip back into the pot. The authors did tests with an induction cooker according to the Indian standard with a lid on the pot, heating water up to 95 °C; only one gram of water

was lost that could be attributed to evaporation. For practical purposes, water evaporation can be ignored during the HTP and Indian standard tests.

In the Indian standard and the HTP testing methods, the effective heat includes heat absorbed by the pot because it is considered that the heat absorbed by pot and the lid could be transferred to the water in the pot. For example, if the total mass of the pot and the lid is 700 g, the heat absorbed by pot and lid might introduce a significant influence on the energy efficiency calculation. The specific heat of aluminium is 0.88 [kJ/(kg °C)]. If the temperature rises from 20 °C to 100 °C, the heat absorbed by the pot could be estimated according to Eq. (3).

$$H_3 = 0.88 \times [(G_p + G_l) \times (T_{p2} - T_{p1})] = 49.3 \text{ kJ} \quad (3)$$

Where,  $G_p$ =Mass of the pot and lid (if the stove was tested with lid on, if not just the mass of the pot), [kg];  $T_{p1}$ =Initial water temperature, [°C];  $T_{p2}$ =Temperature of pot when pot is swapped, [°C]; and 0.88 is specific heat capacity of aluminium, [kJ/(kg °C)].

The energy content (or calorific value) of the corn stalk briquette fuel used for tests was 16,720 kJ/kg, determined in a bomb calorimeter. The energy content of the solid alcohol block used as fire starter was 30,000 kJ/kg, which was a nominal value. The mass of water in the pot was 5.0 kg, the fuel used for tests was 1.5 kg, and the mass of fire starter was 50 g. The results indicated that the heat absorbed by the pot accounted for 0.18% of the energy available in fuel consumed. So this quantity of heat might introduce a maximum 0.18% difference in energy efficiency calculation. This small value can be safely neglected, which allows the computational formula to be straightforward and convenient. However, if an Indian standard 2.2 kg brass pot is used, or any of the 28 standard pots described in Indian standard (IS13152), different answers will be obtained. For example, if the mass of an iron pot is 10 kg (specific heat capacity of iron is 0.46 kJ/(kg °C) and keeping other conditions constant, the same calculation of the heat absorbed by the pot accounts for 1.4% of the energy available from the combustion of fuel. Unfortunately, the influence is not confined to this 1.4% difference. The percentage impact on the calculated value also varies with the mass of water that used. If a heavy pot is half-filled, the effect of ignoring the thermal mass of the pot is doubled compared with filling it full. Such influences cannot be overlooked. The heat absorbed by the pot should be regarded as effective energy because the influence depends on the specific heat capacity of the pot material, the mass of the pot and the influence varies according to the mass of water loaded for the test.

If the protocol adopted specifies the lid-off conditions and effective energy include latent heat of vaporization, then the relative contribution of the sensible heat rise of the pot temperature may be reduced, but vary. How the energy efficiency metric is defined is crucial because it serves as a foundation for subsequent calculations of the reporting metrics. If this term is not precisely defined and correctly calculated, multiple systematic errors may be introduced into subsequent calculations.

#### 4.5. Effective mass of water boiled during a test

Boiling water is a task that requires a change in enthalpy. Thermal efficiency is determined by combining the enthalpy change in water and the energy needed to evaporate. There is a fixed heat loss from a pot related to its conduction, convection and radiative properties whether or not there was a lid covering it. The heat gained by the pot and subsequently lost by those mechanisms is ignored because this part of energy provides no net benefit to cooking. Therefore, when one calculates the specific energy consumption for boiling, the effective mass of water boiled must be well determined. In almost all stove testing standards and protocols, except low power phase in WBT 4.2.3, water at the beginning of the test is regarded as the effective mass of boiled water. Also, the weight is 'adjusted' for any difference between the official local boiling point (as determined by the procedures in the

test method) and the maximum temperature achieved during that testing phase, in spite of the enthalpy change for the total temperature rise already having been considered. For the low power (simmering) phase, the mass of water used for calculating the energy absorbed by the water temperature change is the average of the initial mass and the effective mass of water simmered in the pot [9].

#### 4.6. The thermal efficiency formula used for the high power phase

In WBT 4.2.3, there are two high power phases specified (cold-start with high power using a cold stove, and hot-start with high power using a hot stove), followed by one low power phase (the ‘simmering’ phase). It must be clarified from the outset that the WBT 4.2.3 does not determine the energy efficiency based on the mass of fuel consumed per replication of the test, but rather the thermal efficiency based only on the energy theoretically released from any missing fuel mass. In WBT 4.2.3, thermal efficiency of the high power phases are calculated as follows in Eqs. (4) and (5) [9]:

$$\eta_c = \frac{4.186 \times (T_{cf} - T_{ci})(P_{ci} - P_c) + 2 \cdot 260 \times w_{cv}}{f_{cd} \cdot LHV} \quad (4)$$

$$\eta_h = \frac{4.186 \times (T_{hf} - T_{hi})(P_{hi} - P_h) + 2 \cdot 260 \times w_{hv}}{f_{hd} \cdot LHV} \quad (5)$$

where,  $\eta_c$ =Thermal efficiency (cold start), [%]; 4.186 is specific heat of water, [kJ/(kg °C)];  $T_{cf}$ =Final water temperature (cold start), [°C];  $T_{ci}$ =Initial water temperature (cold start), [°C];  $P_{ci}$ =Initial mass of pot with water (cold start), [g];  $P_c$ =Mass of empty pot (cold start) [g]; 2,260 is the average latent heat of vaporization at the average evaporation temperature, [kJ/kg];  $w_{cv}$ =Mass of water evaporated (cold start), [g];  $f_{cd}$ =Equivalent dry fuel mass consumed (cold start) calculated by deducting the energy content of all residual fuel from the total energy available in the fuel consumed per replication and converting this energy value into a dry fuel mass equivalent, [g];  $LHV$ =Net calorific value (dry fuel), [kJ/kg];  $\eta_h$ =Thermal efficiency (hot start), [%];  $T_{hf}$ =Final water temperature (hot start), [°C];  $T_{hi}$ =Water temperature at the beginning of the test (the hot start), [°C];  $P_{hi}$ =Initial mass of pot with water (hot start), [g];  $P_h$ =Mass of empty pot (hot start), [g];  $f_{hd}$ =Equivalent dry fuel mass consumed (hot start) calculated by deducting the energy content of all residual fuel from the total energy available in the fuel consumed per replication and converting this energy value into a dry fuel mass equivalent, including an assumption that the residual fuel mass is the same for the hot start as was found in the cold start, [g].

The concatenation of errors resulting from the adjustment of the water mass that boiled based on the official boiling point, the assumption of the mass of residual fuel during the hot start, the failure to consider the effect of the thermal mass of the pot and the confusion created by reporting the thermal efficiency instead of the energy efficiency is complicated by the use of a ‘dry fuel equivalent’ in the denominator. This ‘dry mass equivalent’ is then used to calculate a ‘specific fuel consumption’ in g/L water boiled. This is misleading on three counts: the number of liters of boiled water is incorrectly based on the water mass remaining, that mass is adjusted for any difference between the local boiling point and the temperature actually reached, and the ‘mass of fuel’ is not the actual fuel needed to replicate that phase of the test but the dry fuel mass equivalent of the energy value used to calculate the thermal efficiency metric. That ‘dry fuel mass equivalent’ is ultimately presented as the ‘fuel consumption’ which can be misleading when the energy in the residual mass of fuel (char) is a significant portion of the total fuel energy required to complete the tests.

#### 4.7. The latent heat of water vaporization

The value of the local boiling point is related to the end-point of

thermal performance testing and the latent heat of water vaporization, which is 2,256.6 kJ/kg at 100 °C and pressure of 101.3 kPa. The lower the temperature and the pressure are, the larger is the latent heat of water vaporization [53]. However, in WBT 4.2.3, the latent heat of water vaporization is fixed at the value of 2,260 kJ/kg [9]. This value is incorrect and in any case, varies with the local boiling point. For other standards and protocols, the value assigned to the latent heat of vaporization is 2,257 kJ/kg at 100 °C (the theoretical boiling point). Any new standards and protocols should consider the average latent heat of vaporization at evaporation temperature, and the local altitude/atmospheric pressure should be taken into account. Otherwise, the use of a fixed value of latent heat during vaporization will introduce systematic errors.

#### 4.8. The thermal efficiency formula for the simmering phase

Simmering task (the low power phase task) requires maintaining the temperature of water in the pot at a temperature, a little below the local boiling point. This task does not require any positive change in the enthalpy of the pot, and in fact allows for a cooling loss. As ‘simmering’ is not a scientifically defined term, the permissible temperature range for the water in the pot is provided in the WBT. The energy required to keep the pot hot and water evaporation rate are influenced by the fact that the pot is allowed to cool during this phase of the test. Research by Ding et al. found that the ‘thermal efficiency’ of a simmering stove was more controllable and accurate when the WBT was conducted at 2 °C below the boiling point [54].

The calculation of thermal efficiency during simmering phase differs from the two high power phases. Thermal efficiency in WBT 4.2.3 for the simmering phase is determined as in Eq. (6) [9].

$$\eta_s = \frac{4.186 \times (T_{sf} - T_{si})(P_{si} - P_s + w_{sv})/2 + 2 \cdot 260 \times w_{sv}}{f_{sd} \cdot LHV} \quad (6)$$

Where,  $\eta_s$ =Thermal efficiency (simmering phase), [%];  $T_{sf}$ =Final water temperature at end (simmering phase), [°C];  $T_{si}$ =Water temperature at the beginning (simmering phase), [°C];  $P_{si}$ =Initial mass of pot with water (simmering phase), [g];  $P_s$ =Mass of the empty pot (simmering phase), [g];  $w_{sv}$ =Effective mass of water simmered, [g];  $w_{sv}$ =Mass of evaporated water (simmering phase), [g];  $f_{sd}$ =Equivalent dry fuel mass consumed (simmering phase), [g];  $LHV$ =Net calorific value (dry wood), [kJ/kg].

There are multiple problems with this calculation as shown in Eq. (6). It ignores the change in the enthalpy of the pot material. It then credits that same half-mass as having been evaporated at the local boiling point instead of at the simmering temperature. As the task has no implicit requirement to evaporate water, such ‘work done’ should not contribute to the ‘efficiency’ for this task. The output of this equation reports the effectiveness with which energy, beyond the needs of simmering, is wasted, and even then, calculates it incorrectly. The more energy that is lost beyond the requirements of simmering, the better the reported ‘performance’ is. This goes beyond being a systematic error. The metric, as defined, is unfit for purpose.

The enthalpy change in the cooling water should only be applied to the final mass. Therefore, the formula should be as follows in Eq. (7).

$$H_4 = 4.186 \times P_f \times (T_{sf} - T_{si}) \quad (7)$$

Where,  $H_4$ =enthalpy change, [kJ];  $P_f$ =Final mass of water in the pot, [kg];  $T_{sf}$ =Final water temperature (simmering phase), [°C];  $T_{si}$ =Water temperature at the beginning of test (simmering phase), [°C].

Note that the result of this calculation is a negative number as it gives the drop in enthalpy.

Simmering requires only that the energy lost from the pot be replaced, remembering that a permitted reduction in enthalpy might theoretically yield a negative efficiency value. Once cooled to the lower limit of the simmering temperature range, the convective, conductive

and radiative energy losses from the pot must be continuously replaced. This energy requirement is the ‘work done’ and the fuel consumption represents energy value in the denominator.

It is difficult to control the simmering phase within the specified temperature limited, especially for devices such as a Chinese stove burning densified solid pellets. Therefore, the determination of low power performance needs further investigation and refinement.

#### 4.9. Averaging of thermal efficiency in the IWA

In February 2012, at Hague, the Netherlands, more than 90 stakeholders from public and private sectors representing more than 20 national institutes worked together to establish an ISO IWA providing interim guidance for cooking stoves in the following four aspects: efficiency, total emissions, indoor emissions, and safety [4,9]. This ISO IWA serves as a guideline for governments, policy-makers, investors, manufacturers and others. This document influences current efforts to develop further international biomass stove standards and protocols. It made reference to several existing standards and protocols for the rating performance in a laboratory setting. In spite of efforts made before and during the workshop, some of the WBT 4.1.2 calculations (and its subsequent versions) are unreasonable. In IWA, for the performance metric, it said, if the hot start phase were carried out, the average of the cold start efficiency and hot start efficiency could be regarded as the thermal efficiency of high power, which is calculated as shown in Eq. (8) [9].

$$\eta_H = \frac{\eta_c + \eta_h}{2} \quad (8)$$

Where,  $\eta_H$ =Thermal efficiency of high power, [%];  $\eta_c$ =Thermal efficiency of cold start, [%];  $\eta_h$ =Thermal efficiency of hot start, [%].

The reason for conducting a cold and hot start is because it is assumed that different initial conditions will yield different results, i.e. different efficiency and emissions performance ratings for those two stages. The calculation of efficiency for hot start incorrectly assumes the mass of charcoal remaining will be the same as that after the cold start phase. Efficiency is a ratio. Whether a pair of efficiencies can be averaged depends on the circumstances. For thermal efficiency values from different initial conditions, averaging is not permissible. The average of  $A/B$  and  $C/D$  is not simply calculated as  $(A/B+C/D)/2$ . It is  $(A+C)/(B+D)$  [55–57]. Already in problems for reporting the thermal efficiency instead of the energy efficiency (because the energy efficiency is a proxy for fuel consumption), the WBT definition of average thermal efficiency for the different test phases should be calculated as the total energy absorbed by the pot and contents water divided by the energy theoretically released from fuel combustion. It should, of course be reporting the energy efficiency, which is the sum of energy absorbed by the pot and contents divided by the energy available in the fuel consumed per replication of the task. Simply averaging thermal efficiency values are mathematically unacceptable. In theory, the energy needed to bring water to boil would be the same for both test phases. If this equivalence is acceptable, then the average of  $A/B$  and  $A/D$  can be averaged using a harmonic mean as shown in Eq. (9).

$$\eta = \frac{2A}{B + D} \quad (9)$$

Where,  $\eta$ = the average of  $A/B$  and  $A/D$ .

#### 4.10. Influence of fuel type and size

Some stove standards and protocols gave stipulations for fuel, such as Chinese standard NY/T 2370-2013, which specifies that the standard set for stoves that burning biomass briquette [45]. The Indian standard (IS13152) states that “The fuel should be Kail/Deodar/Mango/Acacia cut from the same log into pieces of 3 cm × 3 cm square cross-section and length of half the diameter of combustion

chamber” [42]. WBT 4.2.3 suggests that “Fuel with the cross section between 1.5 cm × 1.5 cm and 3 cm × 3 cm can be used. It further advises that if a comparison of testing results among laboratories is one of the goals, the WBT protocol recommends using wood with cross-sectional dimensions of 1.5 cm × 1.5 cm” [9].

An argument is made that to develop international standards and protocols, the fuel used in the tests should be uniform, whether or not that fuel will ever be used in real life. The assumption underlying this requirement for uniformity is that the inherent performance of the stove can be estimated independent of the type, size and quality of the fuel. While it is technically possible to burn a standardized fuel in many solid fuel stoves, the resulting values of the reporting metrics will be deficient in two major respects. Firstly, if the stove was not designed for the standard fuel, then it is unlikely to perform optimally when burning it and will be inevitably under-perform compared with a stove design optimized for that standard fuel. Thus the stated intention of having an international comparative test assessment of different stoves is undermined and offers little value. The second point is that the ratings will make little to no useful prediction of what the performance of the stoves will be in the field. People will use any readily available fuel. This fallacy about the need for a ‘standard fuel’ is a fatal assumption. The cooking system to be evaluated comprises the stove and the fuel for which it is designed, applied to a cooking regimen typical of some culture and environment. Any testing protocol devised for international use must be structured such that it allows a stove and matching fuel to be evaluated as an integrated system and applied to a known context of use. If the intent is to use the result as a predictor of field performance, then the fuel(s) selected should be those available, or to be made available, in the anticipated communities of use.

The substitution of a ‘test fuel’ for local fuels may have played a role in contributing to the failure of improved stove programmes where laboratory performance ratings were poor predictors of performance in use [58].

Given that the performance of any particular stove design is dependent on the fuel type, and species, its moisture content, size and shape, and that there can be wide variation even within a community, it is necessary that any test report should give comprehensive details of fuel characteristics. Those details are required in addition to the usual fuel parameters such as the calorific value and elemental composition. Stove performance tests should incorporate a fuel specification template, stipulating the types, moisture content, sizes and preparation. Thus different laboratories can take this into account when considering one or another fuel/stove/test sequence and its relevance to their local contexts of use.

#### 4.11. Actions of the testing operator

None of the stove standards and protocols guide the allowed actions of the operator during the tests. Specifically, with regard to refuelling and fire tending, operator actions can have gross influences on the testing results.

A traditional Chinese biomass burning semi-gasifier stove with chimney was tested at China Agricultural University stove testing laboratory with different ventilation rates to explore the influence of operator actions across the usual range of operating conditions of the tested stove. The tests were conducted following Chinese standards NY/T 2369-2013: General technical specification of domestic biofuel cooking stove, and NY/T 2370-2013: Test performance method of domestic biofuel cooking stove. The four testing conditions were: (i) natural draft primary air and natural draft secondary air; (ii) forced primary air and natural draft secondary air; (iii) natural draft primary air and forced secondary air; and (iv) natural draft primary air and no secondary air (Fig. 1 shows the structure of the stove used for those tests). Thermal efficiency values from the four conditions were significantly dissimilar, spanning a range of 8.7~12.5%, while the maximum changes of cooking power observed ranged from 1.75 to

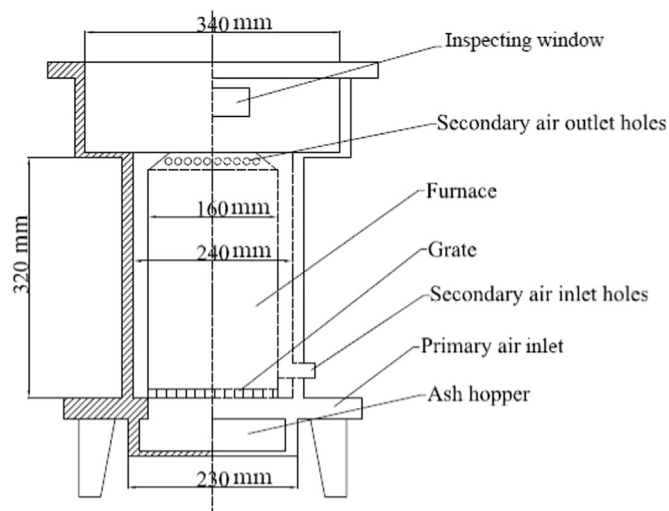

Fig. 1. The structure of the stove used for the four-condition tests.

2.56 kW. Different operators and combustion control operations had substantial influences on the performance rating. Current performance testing standards and protocols for biomass stoves have detailed provisions for many aspects of the test, but few requirements for the operator and operations. Operator actions are difficult to specify, difficult to control and may introduce significant random or systematic errors, especially during refuelling or pot-switching processes. It is suggested that performance testing standards and protocols should provide detailed guidance on what kinds of operations are permitted, and explicit instructions and illustrations so that the operators can follow the procedures that established by the anticipated context. China has a saying about traditional stove testing “Thirty percent depend on the stove, and seventy percent rely on the operator”, which implies the operator has a greater influence on the performance rating than any inherent characteristics of the stove itself.

#### 4.12. Differences between stoves

Owing to inhomogeneous local conditions, widely varying cooking habits, the level of industrialisation and cultural preferences, biomass stove dissemination and use differ widely between/among countries and regions. For example, stoves used in China for cooking and heating are presented in Figs. 2 and 3. Fig. 2 shows a typical household biomass cooking stove, with dimensions of (L × W × H) 380 mm × 380 mm × 500 mm, and mass of 57 kg. Fig. 3 shows a combined biomass fueled cooking and heating stove, with dimensions of 680 mm × 445 mm × 950 mm and weight of 64 kg. The thermal mass of Chinese biomass stoves is quite substantial. Almost all such stoves used in China have chimney so that emissions can be sampled directly from the flue for emission performance evaluations. However, the ranges of temperature and particulate matter concentration should be determined in preliminary measurements. Otherwise, sensitive instruments used for particulate size distribution measurement might be overloaded and damaged. Accordingly, dilution and cooling systems have been introduced as part of the apparatus. Low-mass biomass stoves without chimney are rarely used in China.

Combined cooking and space heating stoves are employed in the majority of Mongolian dwellings. A traditional Mongolian biomass stove, shown in Fig. 4, has dimensions of 460 mm × 300 mm × 300 mm, weighs only 15 kg. This is a radiant space heating stove; so the stove is designed with low thermal mass to obtain excellent heat dissipation performance. Their modern replacements weigh from 40 kg to over 100 kg.

Biomass stoves commonly used in other countries, such as Uganda, Laos, and Nepal are shown in Figs. 5–7, respectively. Most of those



Fig. 2. Biomass cooking stove used in China. Source: Key Laboratory of Clean Production and Utilization of Renewable Energy, Ministry of Agriculture, P. R. China, Bioenergy and Environment Science & Technology Laboratory, College of Engineering/Biomass Engineering Center, China Agricultural University.



Fig. 3. Biomass cooking and heating stove used in China. Source: Collected during the 10th China Stove Exhibition held in Langfang, Hebei Province, China in 2016.

products are smaller compared with conventional Chinese and Mongolian stoves. Household cooking stove used in other countries were shown in Fig. 8.

As there are so many different designs of biomass stoves and diverse kinds of fuels, how could one find a single test method that can cover all stove/fuel combinations? For a start, any testing methods for chimney stoves may not be suitable for testing stoves that do not have a chimney, especially for emission performance tests. Emission tests of





**Fig. 4.** Traditional stoves used in Mongolia. Source: Prof. Lodoysamba Sereeter, National Stove Testing Laboratory in National University of Mongolia, collected during Senior Training Program on Ecological Civilization and Climate Change, Beijing, China, 2013.

chimney stoves sample directly from the stack. For stoves without chimney, it is common to collect the exhaust gases using a capturing hood, and then perform sampling from the diluted gas stream. A substantial difference in results has been reported when applying different standards and protocols [59]. Protocols designed for testing cooking stoves are often unsuited to testing space heating stoves.

#### 4.13. The influence of thermal mass

The WBT 4.2.3 protocol recommends, “A full set of tests should always include all three testing phases”. A rapid test, for internal laboratory use only, may include just the cold start and simmering phases if the stove has a low mass (thin materials, no ceramic lining). When the thermal mass is low, testers have shown that the cold-start and hot-start phases produce similar results [9]. WBT 4.2.3 points out

that the fuel consumption rate during the simmering phase is noticeably influenced by the heat energy stored in the thermal mass of high mass (ceramic) stoves. Stoves with a high thermal mass can store much more heat during the high-power phase, which immediately precedes the much longer simmering phase. If one is using the WBT 4.2.3, this stored heat will be beneficial during the simmering stage. High-mass Chinese and Mongolian stove tests result ought not to be compared low-mass stoves unless the test correctly determines the impact (both positive and negative) of the thermal masses. If a unified protocol favours one or the other, it might introduce significant systematic errors.

## 5. Conclusions and recommendations

Although there are already many biomass stove standards and protocols based on boiling water, many contain multiple systematic and conceptual errors. In the interests of promoting the universal adoption of clean and efficient stoves, the current investigation has examined a few existing standards identifying errors that must be corrected or avoided when developing an international standard. Based on the proceeding, recommendations for the development of testing standards and protocols for biomass stoves are as follows:

- The context of use in different countries should be considered fully during new standards development, such as convenience, ease of the operation, and appropriateness to local customs. The study of existing practices should precede designing of any new testing protocol. Food preparation and cooking practices are profoundly beneficial in society. For a broadly acceptable standard, testing procedures should be bound to existing customs.
- All reporting metrics should be carefully re-evaluated to avoid logical and linguistic inconsistency. Specifically, the concept of efficiency of simmering and low power ‘specific’ parameters must be re-examined. Inappropriate averaging of incompatible quantities of ratios for high power and low power (simmering) phases of tests must be avoided.
- As the actions of the operator actively influence the performance of



**Fig. 5.** Biomass stove used in Uganda. Source: collected during Senior training program for Clean Future – Clean combustion technology and its application for rural households & 2014’ Forum of Renewable Energy Promotion in Developing Countries, Beijing, China, 2014.



**Fig. 6.** Biomass stoves used in Laos. Source: collected during Senior training program for Clean Future – Clean combustion technology and its application for rural households & 2014' Forum of Renewable Energy Promotion in Developing Countries, Beijing, China, 2014.

a stove undergoing a test, the sequence of steps should be stipulated in detail. Fuel, stove and operator should be considered as a whole combined system when designing a testing method.

(d) Nowadays, increasing attentions is being paid to factors influencing human health. Indoor air pollution does serious harm to human health and emissions from unvented biomass stoves can be a substantial contributor to indoor air pollution. During the process of the development of new standards/protocols, more attentions should be paid to emission performance tests conducted

in a relevant context. The matter of when in a combustion sequence to end the measurement of emissions must be revisited.

(e) Conversion coefficients should be provided that can convert testing results from their original values into a standard format. This will enable comparison of results from different laboratories and countries. It may be impossible in the short term to convert all reported parameters, however, at least some metrics can be provided.

(f) During the development process of an acceptable standard, the



**Fig. 7.** Biomass stoves used in Nepal. Source: collected during Senior training program for Clean Future – Clean combustion technology and its application for rural households & 2014' Forum of Renewable Energy Promotion in Developing Countries, Beijing, China, 2014.



**Fig. 8.** Biomass stove widely used in developing countries. Source: Jim Jetter, John Mitchell, Seth Ebersviller, Update on the U.S. EPA Stove Testing on Batch-Fueled Stove. ETHOS Conference 2013, Kirkland, WA, USA.

gaps between laboratory and field tests (kitchen conditions) should be bridged so that results derived from two distinct testing locations are coherent. The existing laboratory-based stove tests usually cannot accommodate contextual cooking practices and field conditions. There is thus an urgent need to develop a testing method that will reduce or even eliminate the gaps between laboratory and field level outcomes. An essential component of this solution is to use locally relevant stove/fuel and behaviour combinations as the pre-requisite for testing. High-performance stoves do not function independently of circumstances. They must be powered with the correct fuel type for which they were designed.

- (g) Since the dissemination of improved biomass stoves is mainly undertaken in developing countries, international standards and protocols are of primary interests to those countries. Experts from the most affected countries should work together and be actively involved in the development of such standards.

## Acknowledgements

Views expressed in this article are owned by the authors and do not necessarily represent the policies or formal positions views of their employers or governments. The work was supported by the bilateral China–South Africa MoST–NRF joint project “Development of Scientifically Robust and Culturally Appropriate Metrics and Protocols for Evaluating Clean (Combustion) Cookstoves”; a grant from the World Bank Group for “China Clean Stove Initiative: Consultant for Developing a Roadmap for Establishing a Sound Stove Standards/Testing/Certification System in China”; the grant from the World Bank Group for “Support Clean Stove Measure under Hebei Pollution Prevention and Control”; the Key Laboratory of Clean Production and Utilization of Renewable Energy, Ministry of Agriculture; College of Engineering/Biomass Engineering Center, China Agricultural University; and Beijing Municipal Key Discipline of Biomass Engineering. The fruitful suggestions and comments provided by the journal referees enabling the authors to improve the paper are duly acknowledged.

## References

- [1] Kshirsagar MP, Kalamkar VR. A comprehensive review on biomass cookstoves and a systematic approach for modern cookstove design. *Renew Sustain Energy Rev* 2014;30:580–603.
- [2] Defoort M, Orange CL, Kreutzer C, Lorenz N, Kamping W, Alders J. Stove manufacturers emissions and performance test protocol—a protocol for testing stove fuel efficiency and emissions and a standard for improved stoves. Fort Collins, CO 80524, USA: Engines and Energy Conversion Lab, Colorado State University; 2002. Available from: (<http://cleancookstoves.org/binary-data/DOCUMENT/file/000/000/73-1.pdf>) [accessed on 27-10-2016].
- [3] Standard Operation Procedure of Sustainable Energy Technology and Research Centre (SeTAR). The heterogeneous testing procedure for thermal performance and trace gas emissions. University of Johannesburg, Johannesburg, South Africa; 2012.
- [4] Sustainable Energy Technology and Research (SeTAR). The heterogeneous testing procedure for thermal performance and trace gas emissions. Johannesburg, South Africa; 2012.
- [5] Makonese T, Pemberton-Pigott C, Robinson J, Kimemia D, Annegarn H. Performance evaluation and emission characterisation of three kerosene stoves using a Heterogeneous Stove Testing Protocol (HTP). *Energy Sustain Dev* 2012;16:344–51.
- [6] Volunteers in Technical Assistance (VITA). Testing the efficiency of woodburning cookstoves: international standards, (ISBN 0-86619-229-8), Volunteers in Technical Assistance, 1815 N. Lynn Street, Suite 200, Arlington, VA 22209, USA.
- [7] Still D, Ogle D, Bailis R. Testing cookstoves. Aprovecho Research Center, Cottage Grove; December 2003.
- [8] Rani CS, Kandpal TC, Mullic SC. Preliminary study of water boiling test procedures used for performance evaluation of fuelwood cookstoves. *Energy Convers Manag* 1992;33:919–29.
- [9] The Water Boiling Test Version 4.2.3 Cook Stove Emissions and Efficiency in a Controlled Laboratory Setting. Available from: (<http://cleancookstoves.org/technology-and-fuels/testing/protocols.html>). [accessed on 02-08-2014].
- [10] ISO-IWA. Guidelines for Evaluating Cookstove Performance. Available at: (<http://community.cleancookstoves.org/files/172>). [accessed on 02-10-2013].
- [11] Kumar M, Kumar S, Tyagi SK. Design, development and technological advancement in the biomass cookstoves: a review. *Renew Sustain Energy Rev* 2013;26:265–85.
- [12] Ruiz-Mercado I, Masera O, Zamora H, Smith KR. Adoption and sustained use of improved cookstoves. *Energy Policy* 2011;39:7557–66.
- [13] Barr, CM. Up in smoke the influence of household behaviour on the long-run impact of improved cooking stoves, 2012 Legislative Drafting Workshop, Drafting Model Laws on Indoor Pollution for Developing and Developed Nations. University Colorado Law School, Boulder, Colorado; 12 July 2012.
- [14] Office of the Spokesperson. The Climate and Clean Air Coalition (CCAC), Fact Sheet, Washington, D.C; 2012.
- [15] Anenberg SC, Kalpana B, James J, Omar M, Sumi M, Jacob M. Cleaner cooking solutions to achieve health, climate, and economic co-benefits. *Environ Sci Technol* 2013;47:3944–52.
- [16] Ochieng CA, Vardoulakis S, Tonne C. Are rocket mud stoves associated with lower indoor carbon monoxide and personal exposure in rural Kenya?. *Indoor Air* 2013;23:14–24.
- [17] The World Bank. Asia sustainable and alternative energy program. Clean Stove Initiative Forum Proceedings. Phnom Penh, Cambodia; 18 Mar 2013.
- [18] World Bank Project to Curb Air Pollution. Improve Health in Ulaanbaatar, Available from: (<http://sd.iisd.org/news/world-bank-project-to-curb-air-pollution-improve-health-in-ulaanbaatar-mongolia/>). [accessed on 25-4-2012].
- [19] Zhang YB, Tuntivate V, Aristanti C, Wu Y. Indonesia – toward universal access to clean cooking. East Asia and Pacific (EAP) clean stove initiative knowledge exchange series. Washington D.C., World Bank. Available from: (<http://documentos.bancomundial.org/curated/es/613191468285612553/Indonesia-Menuju-akses-universal-memasak-bersih-tanpa-polusi>). [accessed on 1-1-2014].
- [20] Editorial. Clean break: improved biomass stoves are not popular; people everywhere deserve modern cooking methods. *Nature*. vol. 509. 2014. p. 533–4. doi: <http://dx.doi.org/10.1038/509533b>.
- [21] Shrestha GR, Upadhyay B. Clean cooking initiatives in Nepal. 2014 Forum of Renewable Energy Promotion in Developing Countries (FREPCD)-2014 Senior training program for clean future-clean combustion technology and its application for rural households, Ministry of Education, China Agricultural University, China, 2014.
- [22] Bailis R, Cowan A, Berrueta V, Berrueta O. Arresting the killer in the kitchen: the promises and pitfalls of commercializing improved cookstoves. *World Dev* 2009;37:1694–705.
- [23] Krishna C. Improved Cook Stoves: Yet to be a Success Story. Available from: ([http://www.bioenergylists.org/files/IMPROVED\\_COOK\\_Stoves\\_Evaluation.pdf](http://www.bioenergylists.org/files/IMPROVED_COOK_Stoves_Evaluation.pdf)). [accessed on 21-2-2012].
- [24] Smith KR, Gu SH, Huang K, Qiu DX. One hundred million improved cookstoves in China: how was it done. *World Dev* 1993;21:941–61.
- [25] Kishore VVN, Ramana PV. Improved cookstoves in rural India: how improved are they? A critique of the perceived benefits from the National Programme on Improved Chulhas (NPIC). *Energy* 2002;27:47–63.
- [26] Sinton JE, Smith KR, Peabody JW, Liu YP, Zhang XL, Edwards R, et al. An assessment of programs to promote improved household stoves in China. *Energy Sustain Dev* 2004;8:33–52.
- [27] Qiu DX, Gu SH, Catania P, Hang K. Diffusion of improved biomass stoves in China. *Energy Policy* 1996;24:463–9.
- [28] The Global Village Energy Partnership (GVEP). Tanzania: Draft Market Assessment Executive Summary. 2012. Available from: [cleancookstoves.org/resources\\_files/Tanzania-executive-summary.Pdf](http://cleancookstoves.org/resources_files/Tanzania-executive-summary.Pdf). [accessed on 08-05-2016].
- [29] Sawe, EN. Wood Fuels Stoves Development and Promotion in Tanzania: Some Selected Experiences. Presentation to the European Biomass/COMPETE Workshop on Bioenergy for Rural Development in Africa and Asia. 30 Jun 2009. Available from: (<http://www.compete-bioafrica.net/events/events2/hamburg/Session%202/S2-5-COMPETE-REImpact-Hamburg-Sawe-090630.pdf>). [accessed on 08-05-

- 2016].
- [30] Bodereau PN. Peruvian highlands, fume-free. Guest Editorial. *Science* 2011;334: [157].
- [31] Johnson MA, Pilco V, Torres R, Joshi S, Shrestha RM, Yagnaraman M, et al. Impacts on household fuel consumption from biomass stove programs in India, Nepal, and Peru. *Energy Sustain Dev* 2013;17:403–11.
- [32] Blunck M, Griebenow C, Rammelt M, Zimm C. Carbon markets for improved cooking stoves: a GIZ guide for project operators. GIZ-HERA-Poverty-oriented Basic Energy Services, Eschborn, Germany; 2011. [63 pp].
- [33] United Nations Framework Convention on Climate Change. CDM > Project Cycle Search > Programme of Activities. Germany. Available from: (<http://cdm.unfccc.int/ProgrammemeOfActivities/index.html>). [accessed on 24-4-2013].
- [34] Fiedler F. The state of the art of small-scale pellet-based heating systems and relevant regulations in Sweden, Austria and Germany. *Renew Sustain Energy Rev* 2004;8:201–21.
- [35] Just B, Rogak S, Kandlikar M. Characterization of ultrafine particulate matter from traditional and improved biomass cookstoves. *Environ Sci Technol* 2013;3506–12.
- [36] Barnes DF, Openshaw K, Smith KR, Plas R. What makes people cook with improved biomass stoves? A comparative international review of stove programs. Washington, D.C. World Bank Tech Pap Number 1994;242.
- [37] Barnes DF, Openshaw K, Smith KR, Plas R. The design and diffusion of improved cooking stoves. *World Bank Res Obs* 1993;8:119–41.
- [38] Krishna PK. Some studies on open fires, shielded fires and heavy stoves. Eindhoven University of Technology, Eindhoven; 1981.
- [39] Bryden M, Still D, Scott P, Hoffa G, Ogle D, Bailis R, Goyer K. Design principles for wood burning cookstoves. Aprovecho Research Center, Cottage Grove, OR; Shell Foundation, London; U.S. Environmental Protection Agency, Washington D.C.; 2006.
- [40] ISO/IEC Directives Part 1: Procedures for the Technical Work, Section 2.3. Available from: ([http://www.iso.org/iso/standards\\_development/processes\\_and\\_procedures/iso\\_iec\\_directives\\_and\\_iso\\_supplement.htm](http://www.iso.org/iso/standards_development/processes_and_procedures/iso_iec_directives_and_iso_supplement.htm)). [Available on 18-9-2016].
- [41] ISO/IEC Directives Part 1: Procedures for the Technical Work, Section 2.6 Submitting drafts – requirements. Available from: ([http://www.iso.org/iso/standards\\_development/processes\\_and\\_procedures/iso\\_iec\\_directives\\_and\\_iso\\_supplement.htm](http://www.iso.org/iso/standards_development/processes_and_procedures/iso_iec_directives_and_iso_supplement.htm)). [Available on 18-9-2016].
- [42] India Standard. Portable solid bio-mass cookstove (Chulha) [The first revision of 13152 (Part 1):1991]. New Delhi, India; 2013.
- [43] Kenya Bureau of Standards. Biomass stoves-performance requirements and test methods. Kenya; 2005.
- [44] Ministry of Agriculture of the People's Republic of China. General technical specification of domestic biofuel cooking stove. NY/T 2370-2013. Beijing, 2013. [in Chinese].
- [45] Ministry of Agriculture of the People's Republic of China. Test performance method of domestic biofuel cooking stove. NY/T 2369-2013. Beijing, 2013. [in Chinese].
- [46] Rob B. Controlled Cooking Test (CCT), Household Energy and Health Programme. Shell Foundation; 2004.
- [47] ISO/IEC Directives, Part 2: Rules for the Structure and Drafting of International Standards. Available from: ([http://www.iso.org/iso/standards\\_development/processes\\_and\\_procedures/iso\\_iec\\_directives\\_and\\_iso\\_supplement.htm](http://www.iso.org/iso/standards_development/processes_and_procedures/iso_iec_directives_and_iso_supplement.htm)). [Available on 18-9-2016].
- [48] Hornby AS, Wehmeier S. The oxford advancedc learner's dictionary of current english (English-Chinese). The Commercial Press and Oxford University Press; 1715.
- [49] Hornby AS, Wehmeier S. The oxford advancedc learner's dictionary of current english (English-Chinese). The Commercial Press and Oxford University Press; 1383.
- [50] Hornby AS, Wehmeier S. The oxford advancedc learner's dictionary of current english (English-Chinese). The Commercial Press and Oxford University Press; 1093.
- [51] International Working Agreement Comments from Sustainable Energy Technology and Research Centre, Johannesburg. Draft Partnership of Clean Indoor Air (PCIA)/ISO (International Organisation for Standardisation)/ANSI (American National Standard Institute) International Workshop Agreement.
- [52] Ding HY. Compare the test methods of thermal and emission performance of household biomass cookstoves [Master's Degree Thesis]. China Agriculture University, Beijing. (in Chinese with English abstract); 2013.
- [53] Yan JL, Yu XF, Wang YQ. The thermodynamic properties chart of water and steam. Higher Education Press; 2004. [in Chinese].
- [54] Ding HY, Liu JX, Zhang YX, Dong RJ, Pang CL. Key factors of thermal efficiency test protocols for household biomass cookstoves. *Adv Mater Res* 2013;268–73.
- [55] Wang YG, Sohn MD, Wang YL, Lask KM, Kirchstetter T, Gadgil AJ. How many replicate tests are needed to test cookstove performance and emissions? - Three is not always adequate. *Energy Sustain Dev* 2014;20:21–9.
- [56] Nauta J. Statistics in clinical vaccine trials. Publisher: Springer Berlin Heidelberg. Print ISBN: 978-3-540-85513-22011, Online ISBN978-3-540-85516-3. 2013.
- [57] Luther W, Brady MD, Theodore E, Yaeger MD. Encyclopaedia of Radiation Pncology. ISBN: 978-3-540-85513-2 (Print) 978-3-540-85516-3 (Online). 2013.
- [58] Commodore AA, Hartinger S, Lanata CF, Mausezahl D, Gil AI, Hall DB, et al. Carbon monoxide exposures and kitchen concentrations from cookstove-related woodsmoke in San Marcos, Peru. *Int J Occup Environ Health* 2013;19:43–54.
- [59] Raman P, Ram NK, Murali J. Improved test method for evaluation of biomass cook-stoves. *Energy* 2014;71:479–95.